

NOTE:
 PIPE STUB-OUT TO BE REMOVED AND REFITTED AS NEEDED TO ACCOMMODATE FUTURE CONNECTION. BREAKOUT OF OPENING WILL NOT BE PERMITTED UNLESS OTHERWISE APPROVED BY THE DISTRICT.

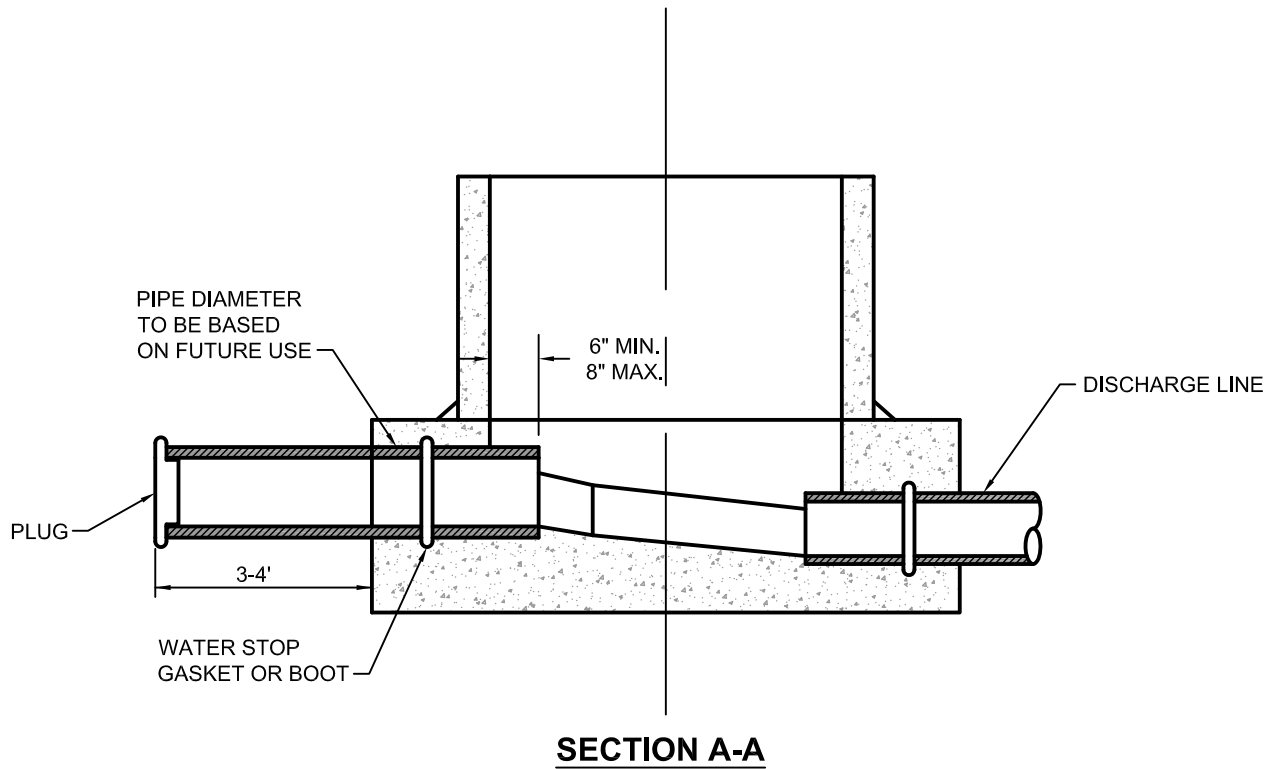

COPYRIGHT © 2016 SOUTHGATE WATER & SANITATION DISTRICTS

REVISED		 Southgate WATER & SANITATION DISTRICTS	SCALE
BY	DATE		NOT TO SCALE
			ISSUE DATE
			FEBRUARY 2016
			SHEET
			1 OF 1
			DRAWING NO.
			SS-10

**MANHOLE STUB-OUT
 (FUTURE CONNECTION)**